

June 20, 1961

L. R. RITCHIE

2,988,946

PICKUP MEANS FOR STRINGED INSTRUMENTS

Filed June 2, 1958

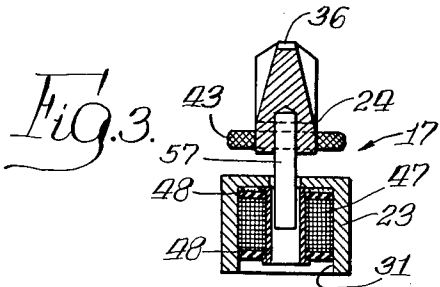
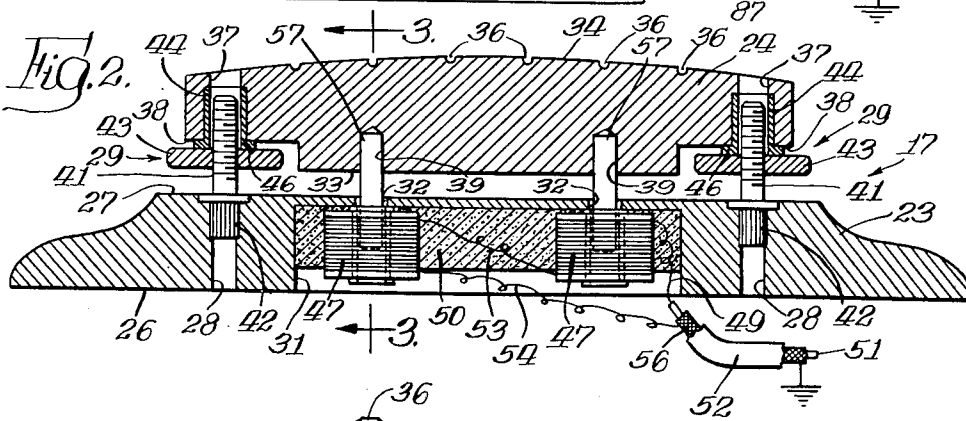
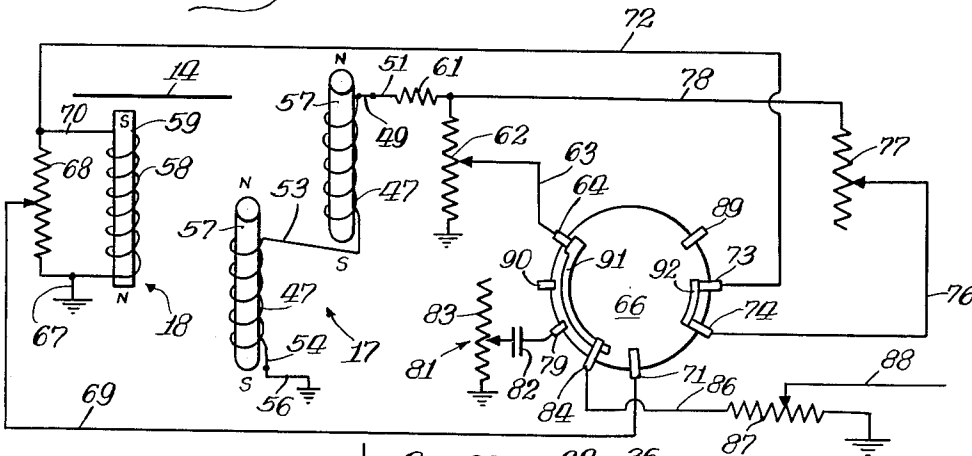
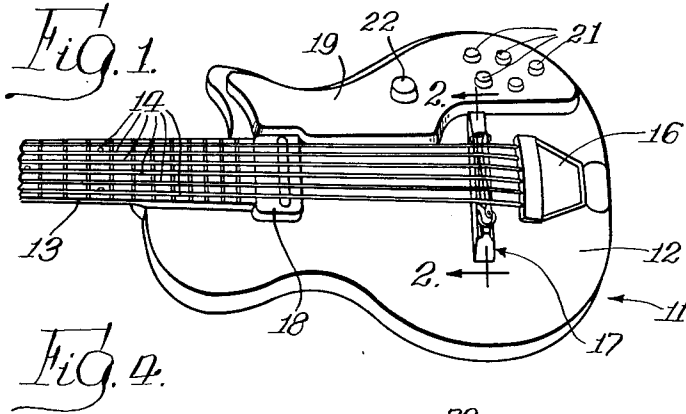

INVENTOR.
Luther R. Ritchie,
BY
Davis, Lindsey, Hobbes & Noyes
Attys.

1

2,988,946

PICKUP MEANS FOR STRINGED INSTRUMENTS
 Luther R. Ritchie, Worth, Ill., assignor to Valco Manufacturing Company, Chicago, Ill., a partnership
 Filed June 2, 1958, Ser. No. 739,218
 13 Claims. (Cl. 84—1.15)

This invention relates to electrical pickup means for musical instruments having strings.

For a great number of years many of the "professional" types of stringed instruments, such as Spanish guitars and the like, have been provided with various types of electric and electromechanical pickup devices that operate through amplifiers to provide additional volume. Also, a number of instruments, such as solid body instruments, depend on such pickup devices and amplifiers for operation. Most of the pickup devices current being used for these purposes are magnetic devices in which magnetic fields are varied by the vibrating action of the strings of the instrument. Although the pickup devices heretofore developed are able to provide many different types of tones, they are not entirely able, in the main, to produce tones having the quality of those from an unaided instrument.

At least part of such inability of previous pickup devices is explained by the fact that such pickups are not responsive to all of the overtone vibrations that are produced by the instrument, and particularly the higher frequency overtone vibrations. It is believed that this is principally due to the fact that many of such high frequency overtone vibrations are not present in the strings of the instrument in front of the bridge. In fact, many such overtone vibrations are secondary vibrations caused by other parts of the instrument in response to the vibrations of the strings. Since the pickup systems using devices of the previous type are usually mounted on the instrument under the strings in front of the bridge, they cannot be responsive to the full range of overtone vibrations produced by the instrument, even though the systems may include several such pickups.

One point of the instrument where many, if not all, of the higher frequency overtone vibrations exist, is in the bridge of the instrument. I have discovered, however, that at the bridge the lower frequency fundamental tone vibrations are relatively weak. I have further discovered that by picking up both the vibrations at the bridge and those in front of the bridge, the combination tone produced by a speaker, after amplification and balancing, is considerably more natural and lifelike and is of higher fidelity than that produced by conventional single or combination pickup systems, even in solid body instruments.

It is, therefore, a primary object of the present invention to provide novel pickup means for stringed instruments, that is adapted to pick up the fundamental vibrations of the strings and to also pick up the higher frequency overtone vibrations to provide a natural, harmonically rich tone after amplification.

Another object of the invention is to provide novel pickup means having a front pickup and a bridge pickup.

A further object of the invention is to provide a novel pickup adapted to serve as the bridge for a stringed instrument.

Still another object of the invention is to provide a novel bridge pickup that senses the high frequency overtone vibrations produced by an instrument at the bridge.

2

A further object is to provide a novel bridge pickup that is simple and inexpensive to produce and that is a self-contained unit.

Other objects and advantages of the invention will be apparent from the following description taken in conjunction with the accompanying drawing wherein:

FIG. 1 is a fragmentary perspective view of an instrument provided with pickup means embodying a preferred form of the invention;

FIG. 2 is a longitudinal sectional view of an enlarged scale showing the preferred form of bridge pickup used on the instrument in FIG. 1 and taken on the line 2—2 of FIG. 1;

FIG. 3 is a cross-sectional view of the structure in FIG. 2, taken along line 3—3; and

FIG. 4 is a diagrammatic view of the pickup means circuit provided for the instrument shown in FIG. 1.

Broadly speaking, the objects of the invention are accomplished by providing pickup means for stringed instruments, comprising a front pickup principally for the lower frequency fundamental vibrations, and a novel bridge pickup principally for the higher frequency overtone vibrations. The front pickup may be a conventional magnetic pickup responsive to vibrations of the strings in front of the bridge and the bridge pickup is a novel device that supports the strings as a conventional bridge and also responds to vibrations at the bridge. Both pickups provide alternating current signal voltages that represent the vibrations to which they are respectively responsive. Means, including a switch, is connected to the pickups for selectively connecting the pickups to amplifier means. When both pickups are used during the playing of the instrument, an harmonically rich tone will be provided by amplifier means to which they are connected, the tone being natural and lifelike in quality.

The present invention may be used on most types of stringed instruments that normally employ a bridge to support the strings intermediate their ends, including solid and hollow body instruments, and is shown in FIG. 1 of the drawing, for illustrative purposes, mounted on a solid body electric Spanish guitar 11. Although the invention is equally usable on hollow body instruments, solid body instruments are almost completely dependent on their pickup-amplifier speaker systems for providing their tone quality and for this reason the present invention will probably be most frequently used on solid body instruments.

The instrument 11 shown in FIG. 1 is a conventional well-known type of instrument and therefore needs little description. Briefly, the instrument 11 comprises a solid non-vibrating body portion 12 and a neck portion shown fragmentarily at 13 and provided with a fingerboard. The instrument 11 has plurality of strings 14 that are of magnetic material, such as steel. The strings are secured at one end of the body portion 12 by a tailpiece 16 and extend across the body 12 and along the neck portion 13 to a plurality of tuning keys (not shown) which adjust the tension in the strings to obtain the desired pitch.

The strings are held in overlying relation to and are spaced from the body portion 12 by bridge means located adjacent the tailpiece 16. In the present instance, the bridge means is a novel bridge pickup 17 which will be described in detail hereinafter, and which rests on the body portion 12 and is engaged by the strings 14. Since

the strings are under tension, the bridge pickup is held firmly against the body portion 12. In addition to supporting the strings 14, the bridge pickup 17 also responds to vibrations at the bridge, which are produced by the strings, and by the body portion in the case of a hollow body instrument. The vibrations at the bridge are principally high frequency overtone vibrations, and the pickup 17 provides an alternating current signal corresponding to such vibrations.

The instrument 11 is also provided with a front pickup 18 positioned on the body portion 12 in front of the bridge pickup between the body portion 12 and the strings 14. In the present instance the front pickup is a conventional magnetic pickup and is positioned on the body portion 12 at the upper end of the neck portion 13. Magnetic pickups of this type are well known and understood in the art and, therefore, need little discussion. The pickup 18 thus may be like that shown in the Keller Patent No. 2,683,388, issued July 13, 1954, and includes an inductance coil and a magnet in inductive relation to the coil. The magnet is positioned so that portions of one polarity are positioned closely adjacent, but not touching, the strings 14. Vibration of the strings 14 varies the magnetic field of the magnet and induces an alternating current signal voltage in the coil which corresponds to the vibrations of the strings. Because of its position in front of the bridge, the front pickup 18 is primarily responsive to the lower frequency fundamental vibrations.

The front pickup 18 and the bridge pickup 17 are interconnected, when desired, in a manner more fully discussed hereinafter, to provide a blended single signal having the frequency characteristics of both signals from the pickups. The means providing such interconnection includes volume and tone controls for each pickup and a switch, and selectively connects the front pickup 18, the bridge pickup 17 and both pickups 17 and 18 to amplifier-speaker means (not shown).

The instrument 11 is provided with a control panel handrest 19 that extends along one side of the body portion 12. The control panel handrest 19 carries a plurality of tone and volume control knobs 21 by which various volume and tone controls, hereinafter described, are manually actuated, and a switch knob 22 by which the switch for selectively connecting the pickups 17 and 18 to the amplifier means is manually actuated, as will be hereinafter described.

The novel bridge pickup 17 in a preferred form is shown in FIGS. 2 and 3. Thus, the pickup 17 comprises a base member 23, a bridge member 24 carried by the base member in overlying relation thereto, and signal generating means embodied in the members. From the drawing, it is apparent that the pickup 17 is self-contained and closely resembles, in shape and size, an ordinary bridge. The fact that the pickup 17 is not noticeably larger than conventional bridges and is self-contained is considered an important feature of the invention. Its self-contained character avoids complex installation procedures, and its resemblance in size and shape to conventional bridges will avoid objections for aesthetic reasons and permits easy substitution for such conventional bridges.

The base member 23 is a unitary elongated element preferably made of wood and externally shaped to conform to base members of conventional two-piece bridges. The base member has a bottom surface 26 shaped to engage the top surface of the body portion of the instrument and a generally flat top surface 27. The ends of the base member 23 are provided with holes 28 extending perpendicularly from the top surface 27 to the bottom surface 26, in which are fitted portions of guide means, indicated generally at 29, for the bridge member 24. The base member also has a central portion hollowed out to provide a recess 31 opening to the bottom surface 26, in which electrical elements of the pickup, hereinafter described, are housed. A pair of longitudinally spaced openings or holes 32 extend from the top surface 27 into the recess 31.

The bridge member 24 carries the strings of the instrument and comprises an elongated unitary element also preferably of wood and carried by the base member in overlying relation on the guide means 29. The bridge member has a substantially flat bottom surface 33 that faces the top surface 27 of the base member, and has a top surface 34 that is arcuate longitudinally of the member and flat transversely of the member. The surface 34 is provided with a plurality of transverse grooves 36 for receiving the strings of the instrument. As shown in FIG. 3, the central portion of the bridge member, where the grooves 36 are provided, is somewhat wedge-shaped in cross-section to provide a reduced area of bearing contact with the strings. The ends of the bridge member 24 beyond the grooves 36 are generally rectangular in cross-section and are provided with holes 37 that correspond to and are axially aligned with the holes 28 in the base member. At its ends, the bridge member 24 is notched at its lower surface, as at 38, to provide clearance for portions of the guide means 29. The bridge member 24 is also provided with a pair of holes or recesses 39 that extend from the surface 33 upwardly, the recesses 39 being in axial alignment with the openings or holes 32 in the base member 23.

The bridge member 24 is movable relative to the base member 23 and in this instance is movable perpendicularly toward and away from the base member in response to vibrations imparted to the bridge member by the strings. The bridge member 24 is supported and aligned relative to the base member by the guide means 29. The guide means 29 also serves as adjusting means for raising and lowering the bridge member relative to base member to accommodate different strings-to-body distances that may be found in various instruments. To these ends, the guide means 29 comprises a pair of threaded rods 41, each having a lower knurled end portion 42 pressed or driven into its associated hole 28 of the base member, thereby preventing relative rotation therebetween. The rods 41 extend upwardly from the top surface 27 and generally perpendicularly to the strings of the instrument. Each of rods 41 is provided with a knurled nut 43 located in a notch 38 in the bridge member and providing bearing support for its associated end of the bridge member 24. The nuts 43 are independently adjustable by hand for raising or lowering their associated ends of the bridge member. The guide means 29 is completed by a pair of guide bushings 44 pressed into the holes or openings 37 in the bridge member. Each bushing has a flange portion 46, the upper side of which engages the bridge member 24 and the lower side of which bears against its associated nut 43. The bore of each guide bushing is large enough to permit the bridge member to move freely toward and away from the base member 23 as the bushings 44 and the rods 41 maintain the members aligned.

The bridge pickup 17 provides an alternating current signal voltage in response to movement of the bridge member 24 relative to the base member 23. By virtue of the engagement of the bridge member 24 with the strings and the base member with the body of the instrument, such movement is caused by the direct action of the strings on the bridge member, and in the case of a hollow body instrument, such movement is also caused in part by secondary vibrations originating in the body. To provide the signal corresponding to such vibrations, the bridge pickup 17 is provided with signal generating means, which in this instance comprises inductance coil means mounted in one of the members and permanent magnet means mounted in the other of the members in inductive relation to the coil means for inducing an alternating current therein upon relative movement between the members.

The inductance coil means can be any number of inductance coils, but in this case two such coils 47 are provided. The coils 47 are mounted in fixed relation in the recess 31 in the base members and in axial alignment with the holes or openings 32 therein. Because the

5

coils 47 are completely encased within the recess 31, they are not subjected to forces tending to dislodge them. As shown in FIG. 3, the coils 47 are provided with insulating end pieces 48, between which the turns of wire are sandwiched. The end pieces 48 are slightly wider than the recess 31 and are wedged between the side walls of the recess when the coils are mounted therein. Potting material, indicated at 50, such as beeswax or the like, is provided to rigidly hold the coils in place.

Although the coils 47 can be connected in parallel, or in series-opposing relation for the elimination of outside interference, I have found it preferable to connect them in series-aiding relation, because the signal produced by each alone is quite weak. Hum introduced by outside interference is not a serious problem and the increased signal strength provided by the series-aiding relationship is advantageous in that the amount of amplification required is reduced. Also, signal strength from the bridge pickup is in better balance for blending with signals from the other pickup. Therefore, one end of the first coil 47 is connected by a lead 49 (see FIGS. 2 and 4) to one conductor 51 of a lead-out cable 52. The other end of the first coil 47 is connected by a lead 53 to the end of the second coil 47 corresponding to the one end of the first coil, and the opposite end of the second coil is connected by a lead 54 to a second grounded conductor 56 in the cable 52. The lead-out cable 52 carries the signal voltage from the coils 47 to means in the control panel 19, connectable to an amplifier.

The permanent magnet means comprises a pair of elongated permanent magnets 57. The magnets 57 are pressed axially into the holes 39 in the bridge member 24 and are held therein by friction. The magnets are sufficiently long to extend through the openings 32 in the base member 23 and axially into their associated coils 47. In the instance shown, the magnets 57 extend slightly more than half way through their associated coils. This position is, of course, subject to change upon adjustment of the bridge member 24 relative to the base member 23 by the guide means 29. The ends of the magnets 57 embedded in the bridge member 24 have the same magnetic polarity; for example, both are "north" magnetic poles.

From the foregoing it must be apparent that an alternating current signal voltage will be induced in the coils 47 by the magnets 57 upon any axial relative movement therebetween, however small the movement may be, and, hence, upon any relative movement of one member toward or away from the other member. The polarity of the signal generated changes with a change in direction of relative movement. Thus, the bridge pickup is responsive principally to the higher frequency vibrations of the strings of the instrument at the bridge point and, in the case of hollow body instruments, is also responsive to all vibrations of the body of the instrument at the bridge point.

FIG. 4 shows a preferred circuit for interconnecting the bridge pickup 17 and the front pickup 18. The bridge pickup is represented by its coils 47 and magnets 57. The front pickup 18 is represented by a coil 58 and a magnet element 59 which may be either a permanent magnet or a pole piece magnetized by a permanent magnet. It should be understood that a conventional pickup device of this character, such as is shown in the above-mentioned patent, usually includes a magnet element such as the element 59 for each string of the instrument and that all have the same magnetic polarity at the end closest to the strings; for example, all have "south" polarity.

In the present system, the magnets of the pickups 17 and 18 are arranged to reinforce each other and provide better field strength for both. To this end, the ends of the magnets 57 closest to the strings are of one polarity and the ends of the magnet elements represented by 59, closest to the strings, are of opposite polarity. In the instance shown in FIG. 4, the upper ends of the

6

magnets 57 are north and the upper end of the magnet element 59 (only one of which is shown) is south. Thus, the magnets 57, the magnet element 59 and the strings 14 cooperate to provide one magnetic circuit of increased field strength for each string rather than independent magnetic circuits at the two pickups.

The two pickups 17 and 18 are connected to switch means operated by the knob 22 for selectively connecting them to amplifier means, tone and volume controls also being provided and operated by the knobs 21. The conductor 49, extending from one of the coils 47, is connected by the conductor 51 through a resistance element 61 to one end of a variable resistance volume control 62. The movable contact of the volume control 62 is connected by a lead 63 to one terminal 64 of a manually operated control switch 66, constituting the switch means.

One end of the coil 58 of the front pickup 18 is connected by a lead 67 to ground. The opposite end of the coil 58 is connected to one end of a variable resistance volume control 68 by a lead 70 and the other end of the volume control 68 is connected to the lead 67. The movable contact of the volume control 68 is connected by a lead 69 to a second terminal 71 of the switch 66. The one end of the volume control 68 connected to the lead 70 is also connected by a lead 72 to a third terminal 73 of the switch 66. A fourth terminal 74 of the switch 66 is connected by a lead 76 to the movable contact on a variable resistance fader tone control 77 and one end of the tone control 77 is connected by a lead 78 to the one end of the volume control 62 connected to the resistance element 61. A fifth terminal 79 of the switch 66 is connected to a grounded tone control device 81 comprising a capacitor 82 and a variable resistance 83. A sixth terminal 84 of the switch 66 is connected by a lead 86 to one end of a variable resistance master volume control 87. The opposite end of the volume control 87 is grounded and the movable contact of the volume control 87 is connected to a lead 88 adapted to be connected to an amplifier.

In addition to the terminals above identified, the switch 66 also includes additional terminals 89 and 90 that can be used for connecting an additional pickup in the circuit, if desired. For example, a pickup similar to the pickup 18, but adapted to be positioned under the strings close to the bridge pickup 17, could be connected to these terminals. The switch is a three-position switch and also includes a pair of arcuately extending, movable contact elements 91 and 92 that move in unison upon rotation of the control knob 22 in FIG. 1.

In the first position of the switch 66, shown in FIG. 4, the element 91 interconnects the terminals 64 and 84, and the element 92 interconnects the terminals 73 and 74. Thus, in this position of the switch 66, the bridge pickup 17 is connected for amplification of its signal by the amplifier through the elements 49, 61, 62, 63, 64, 91, 84, 86, 87, and 88. Likewise the front pickup 18 is connected in parallel with the bridge pickup by elements 70, 72, 73, 74, 76, 77, 62, 63, etc.

In the second position of the switch 66, moving in a counterclockwise direction from the first position, the contact 91 interconnects terminals 90, 84, and 71 and the contact 92 interconnects terminals 73 and 89. Thus, since the terminal 64 is no longer connected, the bridge pickup 17 is disconnected and the front pickup 18 is connected for amplification of its signal through the elements 70, 68, 69, 71, 91, 84, 86, 87 and 88. Any additional pickup that might be connected to the terminals 89 and 90 would be connected in parallel with the front pickup 18, by a similar arrangement of elements connected to the terminals 89 and 90.

In the third position of the switch 66, the contact 91 interconnects the terminals 79, 84 and 71, and the contact 92 engages the terminal 89. In this position, only the front pickup 18 is connected for amplification through

the same elements as in the second position. However, the tone control device 81 is also connected in shunt relation with the pickup 18 to provide tone control therefor.

The various tone control and volume control elements illustrated in the circuit and mentioned above are conventional and well known in the art. Therefore, their operation in the circuit needs no further description. They are regulated by the various control knobs 21 shown in FIG. 1. It should be pointed out, however, that this circuit arrangement also permits an artist to select only the signal from the bridge pickup for amplification. With the switch 66 in its first position, where the pickups 17 and 18 are connected in parallel, the fader tone control 77 may be adjusted for maximum resistance to effectively eliminate the signal from the front pickup. Thus, only the signal from the bridge pickup will be amplified.

It is thus seen that this invention provides novel pickup means for stringed instruments that provides harmonically rich tones by combining and blending signals representative of the lower frequency vibrations in the strings with signals representative of the higher frequency vibration at the bridge of the instrument. The invention includes a novel bridge pickup that is responsive to such higher frequency vibrations and is adapted to be used on solid and hollow body instruments. The bridge pickup is structurally simple, economical to manufacture and is a self-contained unit.

Although the invention has been described in connection with a certain specific structural embodiment, it is to be understood that other and alternative structures may be resorted to without departing from the scope of invention as defined in the appended claims, wherein.

I claim:

1. A bridge pickup for a musical instrument having a plurality of strings extending across a body of the instrument, comprising an elongated base member formed to be seated on top but unattached to the body of the instrument beneath the strings thereof, an elongated bridge member movably mounted on said base member in overlying aligned relation and adapted to support the strings of said instrument whereby the strings will hold the assembled members in position on the body of the instrument, said members having guide means for maintaining said members in said aligned relation, said bridge member being movable toward and away from said base member on said guide means in response to vibrations of the strings on said bridge member, and means mounted in said members and operable upon relative movement between said members for generating a signal voltage alternating in polarity in accordance with changes in direction of movement of said bridge member relative to said base member, said generating means being adapted to be connected to amplifier means.

2. A bridge pickup according to claim 1 in which said generating means comprises at least one permanent magnet mounted in fixed position in one of said members and an inductance coil mounted in fixed relation in the other of said members and in inductive relation with said magnet, said coil being adapted to be connected to amplifier means, whereby upon movement of said bridge member toward and away from said base member a signal voltage will be induced said coil.

3. A bridge pickup according to claim 1 in which said generating means comprises a pair of spaced permanent magnets mounted in fixed positions in one of said members, and a pair of inductance coils mounted in fixed positions in the other of said members corresponding to the positions of said magnets, each coil being in inductive relation with its corresponding magnet, said coils being interconnected and adapted to be connected to amplifier means, whereby upon movement of said bridge member toward and away from said base member a signal voltage will be induced in said coils.

4. A bridge pickup according to claim 3 in which said coils are connected together in series aiding relationship, whereby their signals are additive.

5. A bridge pickup according to claim 3 in which said magnets are bar magnets mounted in said bridge member to extend generally parallel with respect to each other toward said base member with ends of one polarity adjacent their associated coils and ends of the opposite polarity to be adjacent the strings.

6. A bridge pickup for a musical instrument having a plurality of strings extending across a body of the instrument, comprising an elongated base member formed to be seated on top but unattached to the body of the instrument beneath the strings thereof, an elongated bridge member movably mounted on said base member in overlying aligned relation and adapted to support the strings of said instrument whereby the strings will hold the assembled members in position on the body of the instrument, said members having guide means for maintaining said members in said aligned relation, said bridge member being movable on said guide means relative to said base member in response to vibrations of the strings on the bridge member, a permanent magnet mounted in fixed relation in one of said members, and an inductance coil mounted in fixed relation in the other of said members and in inductive relation to said magnet, said magnet and coil relatively moving axially of the coil on movement of said bridge member, whereby a signal voltage will be induced in said coil.

7. A bridge pickup according to claim 6 in which said magnet is mounted in said bridge member and said coil is mounted in said base member.

8. A bridge pickup according to claim 7 in which said base member has a centrally positioned recess, and said coil is mounted in said recess to be substantially enclosed by said base member when the pickup assembly is mounted on an instrument.

9. Pickup means for a musical instrument having a plurality of magnetic material strings extends across a body of the instrument, comprising in combination a front magnetic pickup adapted to be mounted on the instrument under the strings, with the strings on vibration thereof varying the magnetic field of said pickup to provide a signal voltage, a bridge pickup comprising an elongated base member adapted to seat on the body of the instrument, an elongated bridge member carried by said base member and adapted to support the strings of the instrument, said bridge member being movable relative to said base member in response to vibrations of the strings on the bridge member, permanent magnet means mounted in one of said members and inductance coil means mounted in the other of said members in inductive relation to said magnet means to provide a second signal voltage in response to movement of said bridge member relative to said base member, and means interconnecting said front pickup and said bridge pickup to combine said signal voltages into a single signal representative of both, said interconnecting means being adapted to be connected to amplifier means.

10. Pickup means according to claim 9 in which said front pickup and said bridge pickup are connected in parallel to said interconnecting means.

11. Pickup means according to claim 9 in which said interconnecting means includes a manually operable switch for selectively connecting said front pickup means, said bridge pickup means, and said front pickup means together with said bridge pickup means, to the amplifier.

12. Pickup means according to claim 9 in which said front pickup includes magnet means and the polarities of the magnet means in said front pickup and the magnet means in said bridge pickup are oppositely oriented with respect to the strings.

13. Pickup means according to claim 9 in which said front pickup is a magnetic pickup having a magnetic pole of one polarity adapted to be located adjacent said strings, and said magnet means in said bridge pickup comprises a pair of spaced permanent magnets mounted in fixed relation in said bridge member with their ends adjacent

said strings, said ends being of the same polarity as each other and of opposite polarity to said magnetic pole.

References Cited in the file of this patent

UNITED STATES PATENTS

1,707,115	Dierdorf	Mar. 26, 1929
1,861,717	Pfeil	June 7, 1932
2,048,515	Pfeil	July 21, 1936

5

2,049,084
2,074,982
2,455,452
2,683,388
2,784,631

150,348

Severy	July 28, 1936
DiMarzio	Mar. 23, 1937
Van Eps	Dec. 7, 1948
Keller	July 13, 1954
Fender	Mar. 12, 1957

FOREIGN PATENTS

Germany	Apr. 15, 1904
---------	---------------