

Dec. 7, 1937.

R. DOPYERA

2,101,364

NECK CONSTRUCTION FOR A STRINGED MUSICAL INSTRUMENT

Filed June 6, 1936

2 Sheets-Sheet 1

Fig. 1

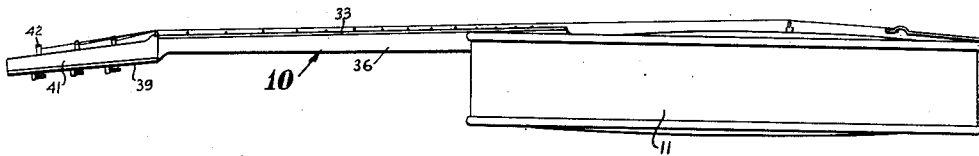

Fig. 2

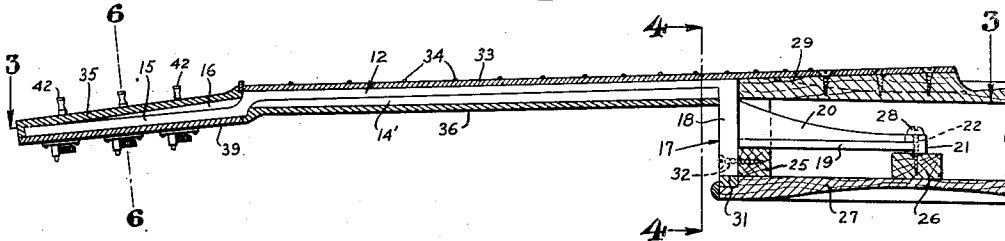

Fig. 3

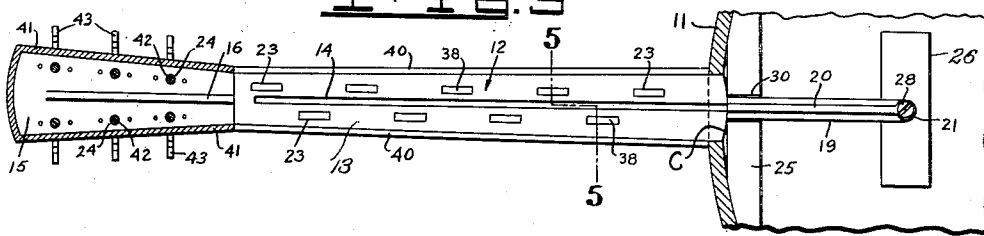

Fig. 5

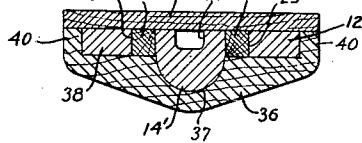

Fig. 4

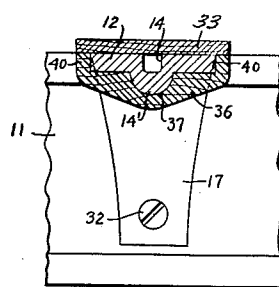
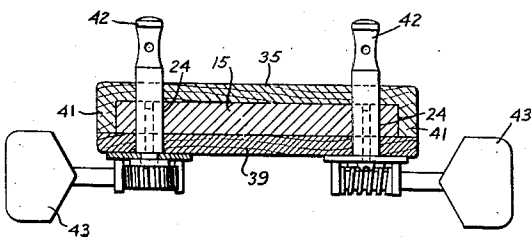

Fig. 6



INVENTOR.
RUDOLPH DOPYERA
BY *R. Dopyera*
ATTORNEY.

Dec. 7, 1937.

R. DOPYERA

2,101,364

NECK CONSTRUCTION FOR A STRINGED MUSICAL INSTRUMENT

Filed June 6, 1936

2 Sheets-Sheet 2

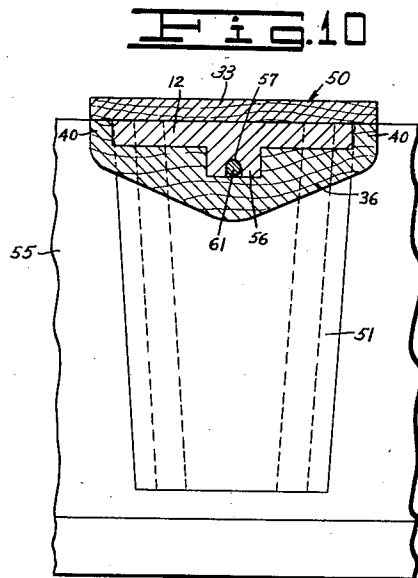
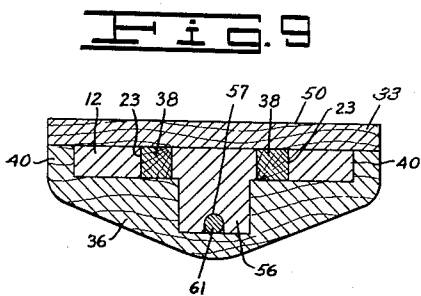
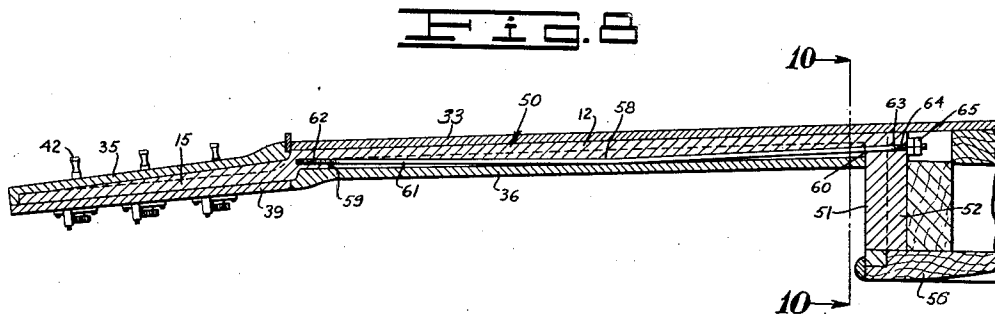
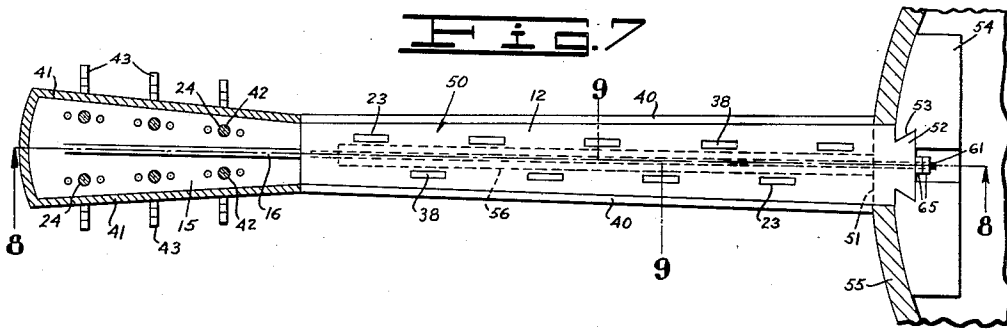

INVENTOR.
RUDOLPH DOPYERA.
BY *[Signature]*
ATTORNEY.

UNITED STATES PATENT OFFICE

2,101,364

NECK CONSTRUCTION FOR A STRINGED MUSICAL INSTRUMENT

Rudolph Dopyera, Los Angeles, Calif.

Application June 6, 1936, Serial No. 83,882

7 Claims. (Cl. 84-293)

This invention relates to an improved neck construction for a stringed musical instrument.

The general object of the invention is to provide an improved neck for use on a stringed musical instrument such as a guitar.

A more specific object of the invention is to provide a metal neck for a guitar wherein the neck is of such construction that all of the strings may be reached with ease.

A further object of the invention is to provide a metal neck for a stringed musical instrument wherein a metal neck is provided with a cover.

Another object of the invention is to provide an improved means for anchoring a metal neck on the body of a stringed musical instrument.

Other objects and the advantages of the invention will be apparent from the following description taken in connection with the accompanying drawings, wherein:

Fig. 1 is a side elevation of a musical instrument showing my improved neck applied thereto;

Fig. 2 is a fragmentary, central, sectional view through the center of a musical instrument;

Fig. 3 is a section taken on line 3-3 of Fig. 2;

Fig. 4 is a section taken on line 4-4 of Fig. 2;

Fig. 5 is a section taken on line 5-5 of Fig. 3;

Fig. 6 is a section taken on line 6-6 of Fig. 2;

Fig. 7 is a view similar to Fig. 3 showing a modification of my invention;

Fig. 8 is a section taken on line 8-8 of Fig. 7;

Fig. 9 is a section taken on line 9-9 of Fig. 7;

and

Fig. 10 is a section taken on line 10-10 of Fig. 8.

Referring to the drawings by reference character I have shown my invention as embodied in a neck which is indicated at 10. This neck is shown as mounted on the body of a musical instrument which may be a guitar and which is indicated generally at 11.

The neck 10 is preferably made of metal of light weight such as cast aluminum and includes an intermediate portion 12 which includes plane top surfaces 13 arranged on opposite sides of a groove 14 which extend substantially the full length of the intermediate portion. A rounded rib 14' is disposed along the bottom of the intermediate portion. The outer end portion 15 has a plane top surface and has a stiffening rib 16 thereon which at one end is integral with the adjacent portion of the intermediate part 12 and at the other end tapers away until it vanishes near the outer end of the neck. The portion 15 is disposed slightly below and is inclined at an angle relative to the portion 12.

The intermediate portion 12 at its inner end is

secured to a foot portion 17 which includes a downwardly extending foot 18 which as shown has plane front and back faces disposed at an angle of slightly less than 90° to the top of the intermediate portion 12 and the foot 17 has a rearwardly extending projection 19 thereon and integral therewith. This projection 19 is reinforced by a rib 20 which is integral with the projection and with the adjacent portion of the foot 17. The part 19 terminates in a round boss 21 which is apertured as at 22.

The intermediate portion 12 is provided with longitudinally extending slots 23 which are disposed on each side of the groove 14 while the portion 15 is provided with apertures 24. In constructing a musical instrument, for example, a guitar having my improved neck applied thereto, the projecting member 19 may be disposed on transverse members 25 and 26 which are secured to the bottom 27 of the guitar.

A screw 28 passes through the aperture 22 and serves to hold the rear end of the member 20 in place. The member 25 extends the full distance between the bottom 27 and the top 29 of the instrument and is notched as at 30 to receive the portion 19 as shown in Figs. 2 and 3. The bottom is rabbeted as at 31 and in this rabbeted portion the lower end of the foot member 17 is fitted. The foot member 17 has a screw 32 passing therethrough which enters the transverse member 25 as shown in Figs. 2 and 4.

The top of the intermediate portion 12 is covered with a suitable wood or other cover member 33 which may have suitable frets 34 thereon while the top of the outer end portion 15 is covered with a suitable wooden member 35. The bottom of the intermediate portion 12 which has a rounded rib is provided with a cover 36 which is preferably of wood and which is suitably recessed as at 37 to receive the rounded bottom 14' of the rib as shown in Fig. 5.

In order that a wood to wood engagement may be made to hold the cover members 33 and 36 the apertures 23 receive wooden blocks 38 and the parts are all glued together as clearly shown in Fig. 5 of the drawings.

The lower face of the outer end portion 15 is provided with a cover 39 as shown in Fig. 6.

As shown in Figs. 4, 5, and 6 the portion 33 is preferably plane on both sides and the portion 36 has side flanges 40 engaging this portion while the part 39 is plane on both sides and the part 35 has side flanges 41 which engage the part 39 so that the construction is reversed in the parts

12 and 15 in so far as the disposition of the side flanges is concerned.

The portion 15 is provided with suitable string receiving members 42 which may be suitably operated by keys 43. The inner end of the foot 18 is curved as at C so that it will be self centering during assembly.

In Figs. 7, 8, and 9 I have shown a modification of my invention wherein the neck 50 is similar to the neck previously described except that the projecting portion 19 is omitted and instead a foot 51 on the end of the neck is provided with a dovetailed projection 52 which fits in a suitable undercut rabbeted portion 53 in a cross block 54 secured to the front 55 and the bottom 56 of the instrument.

Further, in the modification shown the groove 14 is preferably omitted and a projecting rib 56 is provided with a slot 57 which opens downwardly. The slot is preferably shallowest in an intermediate portion 58 and increases in depth to a front portion 59 and a rear portion 60. In this slot I arrange a tension member 61 the front portion of which is threaded at 62 to fit within a similarly threaded portion in the forward end of the intermediate portion of the neck. The rear end of the tension member 61 passes through an aperture 63 in the foot 51 and is threaded as at 64 to receive nuts 65 so that the member 61 may be placed under tension.

Since the high point 58 of the wall of the slot is engaged by the tension member 61 when the nut 64 is tightened tension is placed on the member 61 and this will tend to push upwardly the intermediate portion of the neck so that the proper tension will be secured in the neck.

From the foregoing description it will be apparent that I have invented a novel neck for a stringed musical instrument which is economical in construction and highly efficient in use.

Having thus described my invention I claim:

1. In a stringed musical instrument, a body having a top and bottom member and a side wall, a transverse member on said bottom and spaced from said side wall, a second transverse member in said body adjacent the side wall, a neck having a foot piece thereon engaging said second transverse member, said foot piece having a projection thereon, said second member being slotted and said projection fitting in said slot, said projection having an apertured boss therein, a screw passing through said boss and secured in said first transverse member.

2. In a stringed musical instrument, a body having a top and bottom member and a side wall, a transverse member on said bottom and spaced from said side wall, a second transverse member in said body adjacent the side wall, a neck having a foot piece thereon engaging said second transverse member, said foot piece having a projection thereon, said second member being slotted and said projection fitting in said slot, said projection having an apertured boss therein, a screw passing through said boss and secured in said first transverse member, said neck having a longitudinally extending groove therein and having slots on each side of said groove, said neck having a rib below said groove, said rib having a rounded lower surface, said neck including a front portion having a tapered rib therein, a plurality of string engaging members on said front portion, said neck having a cover member on the top thereof

and having a second cover member on the bottom thereof, one of said cover members having flanges engaging the other cover member, a wooden block in said slots and means to secure said wooden block to the cover.

3. For use in a stringed musical instrument, a neck having a foot piece thereon, said foot piece having a projection thereon, said projection having an apertured boss therein, said neck having a longitudinally extending groove therein and having slots on each side of said groove, said neck having a rib below said groove, said rib having a rounded lower surface, said neck including a front portion having a tapered rib therein, said neck having a cover member on the top thereof and having a second cover member on the bottom thereof, one of said cover members having flanges engaging the other cover member, a wooden block in said slots and means to secure said wooden block to the top and bottom members.

4. In a stringed musical instrument, a neck, said neck being made of metal and having a groove in the bottom thereof, said groove tapering in depth from an intermediate portion towards both ends, a tension member in said groove and anchored at one end thereof, a body, means to secure the neck to said body, said body having an aperture therein, the other end of said tension member passing through said aperture and fastening means on the said other end of the tension member.

5. For use in a stringed musical instrument, a neck, said neck being made of metal and having a groove in the bottom thereof, said groove tapering in depth from an intermediate portion towards both ends and a foot on said neck and adapted to be secured to the body of an instrument.

6. In a stringed musical instrument, a body having a top and bottom member and a side wall, a transverse member on said bottom and spaced from said side wall, a second transverse member in said body adjacent the side wall, a neck having a foot piece thereon engaging said second transverse member, said foot piece having a projection thereon, said second member being slotted and said projection passing through said slot, said projection engaging said first mentioned transverse member and means to secure said projection to said first transverse member.

7. In a stringed musical instrument, a body having a top and bottom member and a side wall, a transverse member on said bottom and spaced from said side wall, a second transverse member in said body adjacent the side wall, a neck having a foot piece thereon engaging said second transverse member, said foot piece having a projection thereon, said second member being slotted and said projection fitting in said slot, said projection having an apertured boss therein, fastening means passing through said boss and secured in said first transverse member, said neck having a longitudinally extending groove therein and having slots on each side of said groove, said neck having a rib below said groove, said rib having a rounded lower surface, said neck including a front portion having a rib therein, and a plurality of string engaging members on said front portion.

RUDOLPH DOPYERA.